

Instructions for installing **DEAD-STOP (2" Pressure Fill)** Overfill Prevention Valve

The DEAD-STOP is a 2" overfill prevention valve with a ZERO leak rate, suitable for above ground commercial diesel storage installations, drum installations, generator belly tanks and pressure deliveries.

With a flow rate of 10 – 500 l/min and a maximum operating pressure of 10 bar (145 Psi) the DEAD-STOP is suitable for a range of applications, protecting against the risk of an over-fill, should other methods fail.



**ALWAYS USE
NON-SPARK TOOLS!**

PLEASE READ CAREFULLY BEFORE INSTALLATION

Fluid compatibility and Materials

The DEAD-STOP valve was designed primarily to be compatible with commercial diesel fuel products. All seals are 'Viton' as standard. If use with an alternative fuel or fluid that is not listed below is required please contact Risbridger Ltd.

Diesel
Bio-Diesel
FAME Blends
Waste Oil – subject to installation with strainers

The materials of the DEAD-STOP overfill prevention valve are as shown below:

Aluminium components	Anodised to BS EN ISO 7599: AA05-15
Stainless steel components	Grade 303
Plastic components	Polyacetal
Mild steel components	C6F free surface coating
Seals	Viton
Floats	High Density Polythene
Fasteners	Grade 304 Stainless steel
Gasket	Nitrile Rubber Bonded Cork

Configuration Options

Stock code	Description
DEAD-STOP	DEAD-STOP valve only
DEAD-STOP-AF	DEAD-STOP valve with adjustable float level

Installation Options

Stock code	Description
4032	2" BSP Weld Socket
3850	2" BSP Lock nut
RIS-FLANGE10F	1" BSP 2" PCAT Flange Kit
RIS-FLANGE15F	1.5" BSPT 2" PCAT Flange Kit
RIS-FLANGE20F	2" BSPT 2" PCAT Flange Kit

RECOMMENDED INSTALLATION TOOLS REQUIRED FOR DEAD-STOP



- 21mm & 70mm spanner
- Torque wrench with 10Nm to 30Nm range minimum
- 13mm socket
- Thread / O-ring Grease
- Bondloc B542 (or equivalent semi-permanent thread sealant)

ALWAYS USE NON-SPARK TOOLS!

DEAD-STOP Dimensions

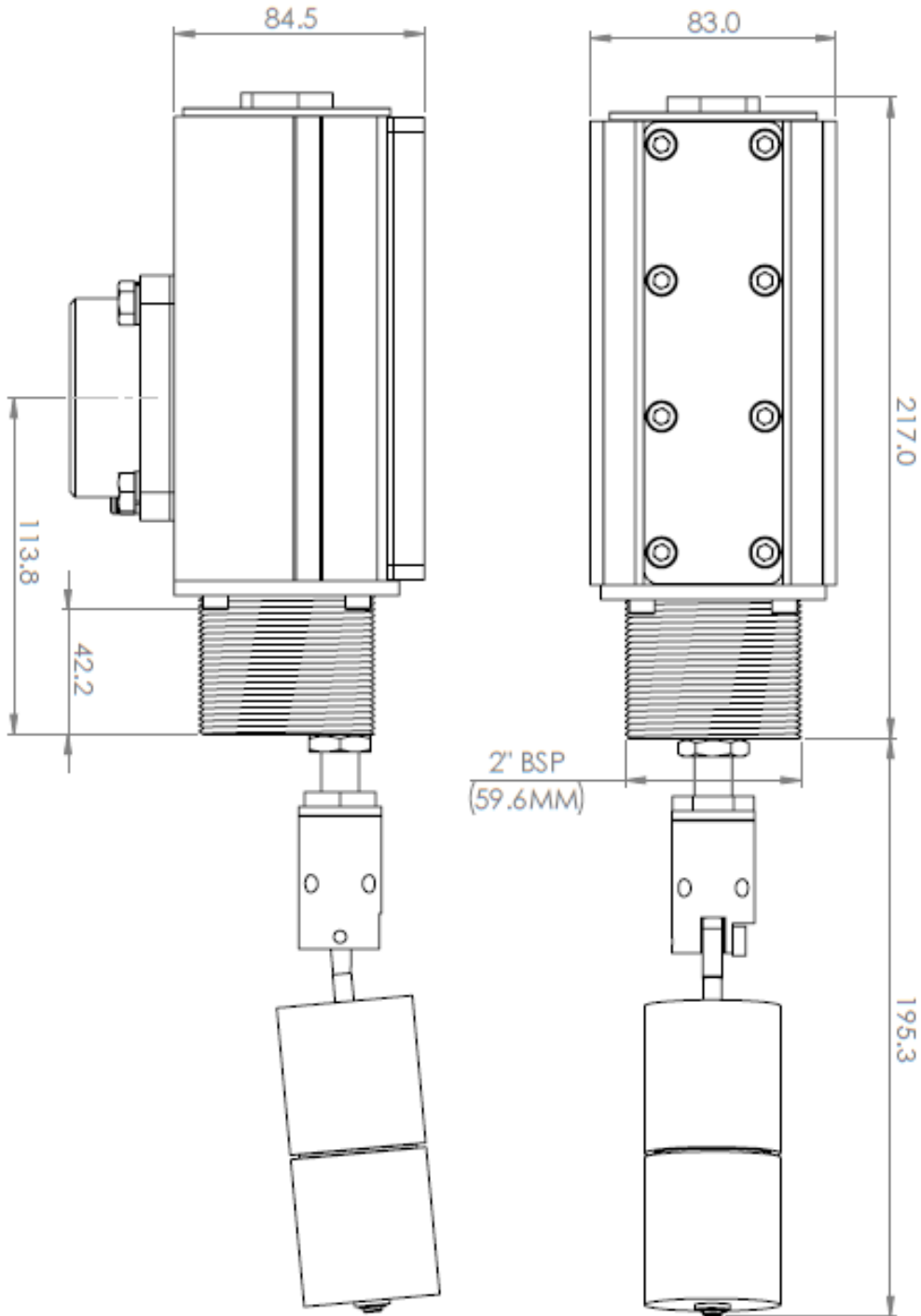

ALWAYS USE NON-SPARK TOOLS!

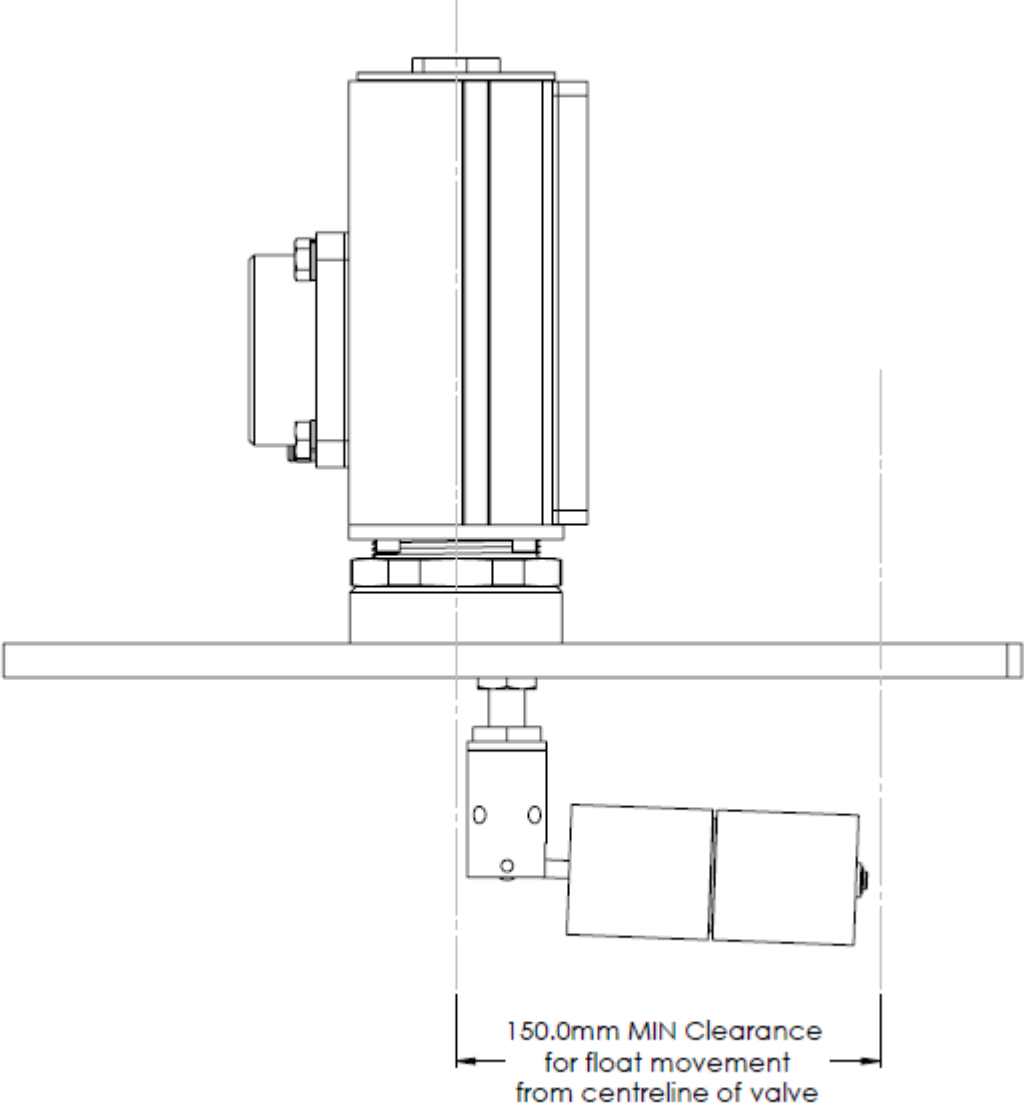

ALWAYS USE NON-SPARK TOOLS!

Note: The fluid shut-off level is approximately 145mm below the bottom of the DEAD-STOP valve using the standard-length float.

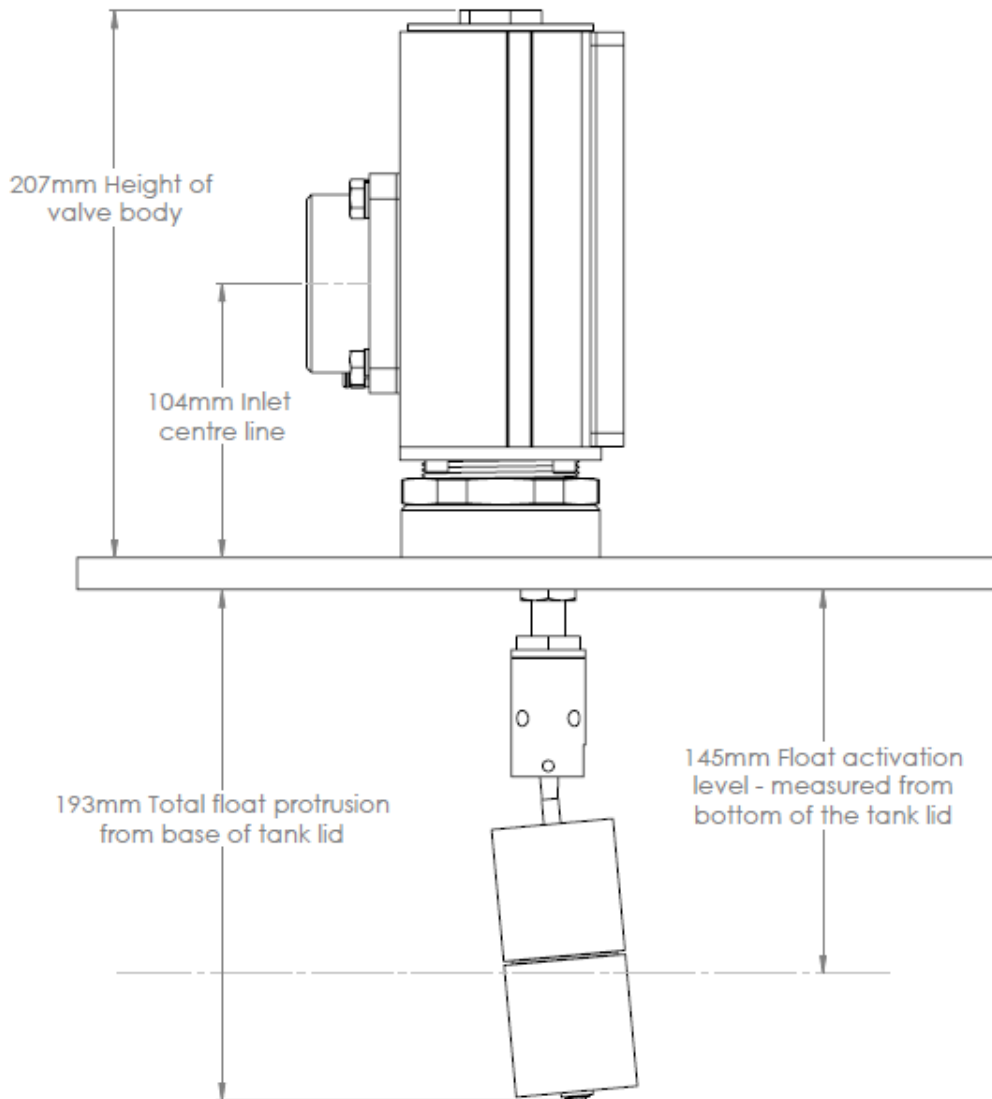

Diagram above shows the layout and installation dimensions for the DEAD-STOP with weld socket installation – Stock Codes: DEAD-STOP, 4032 (weld socket), 3850 (2" BSP lock nut) and a 12mm thick tank lid.

If you require an adjustable float height, we refer you to the adjustable float kit, Stock Code: DEAD-STOP-AF

ALWAYS USE NON-SPARK TOOLS!

Assembly Instructions

The DEAD-STOP will require basic assembly before installation. As standard the two parts will need to be screwed together using a 21mm spanner. As shown in the steps below



Step 1 – Push the drop tube into the threaded hole at the bottom of the main valve until it stops.



Step 2 – Screw the lock nut into the body, ensuring the float is in the desired orientation, typically inline with the front face of the valve, prior to tightening fully with a 21mm spanner.

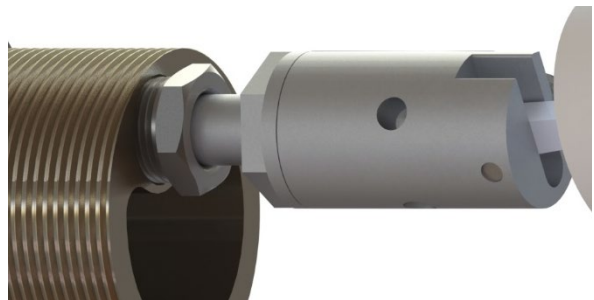

ALWAYS USE NON-SPARK TOOLS!

Installation Instructions

The DEADSTOP valve must be installed in the upright position

For Above Ground Tank Installation using a weld socket you will need stock code DEAD-STOP, 4032 and 3850.

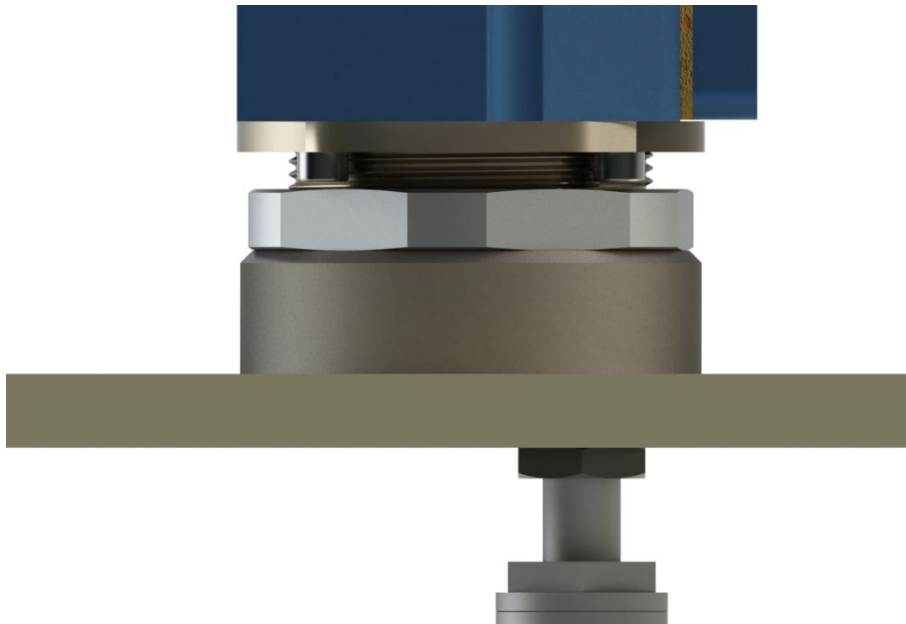

1. At a suitable position on the tank lid cut a 70mm diameter hole.
2. Place the weld socket (4032) in the hole, the shoulder should sit flush with the top of the tank lid.
3. Join to the tank with a full fillet sealing weld.
4. Screw the lock nut (3850) fully on to the DEAD-STOP valve until it is flush against the 4 cap heads at the top of the 2" BSP thread.
5. Screw in the complete valve cartridge so that only 1 or 2 thread pitches remain exposed between the lock nut and top of the weld socket.
6. Rotate the valve body to the correct inlet pipework orientation and tighten the lock nut against the weld socket using a 70mm spanner.
7. Connect the inlet pipework using suitable flange components and tighten the 4 x M8 x 20mm bolts to 27Nm (20ft lbs) torque maximum.

ALWAYS USE NON-SPARK TOOLS!

Installation Instructions

For an alternative installation method as shown, you will need stock code DEAD-STOP and 2 off 3850

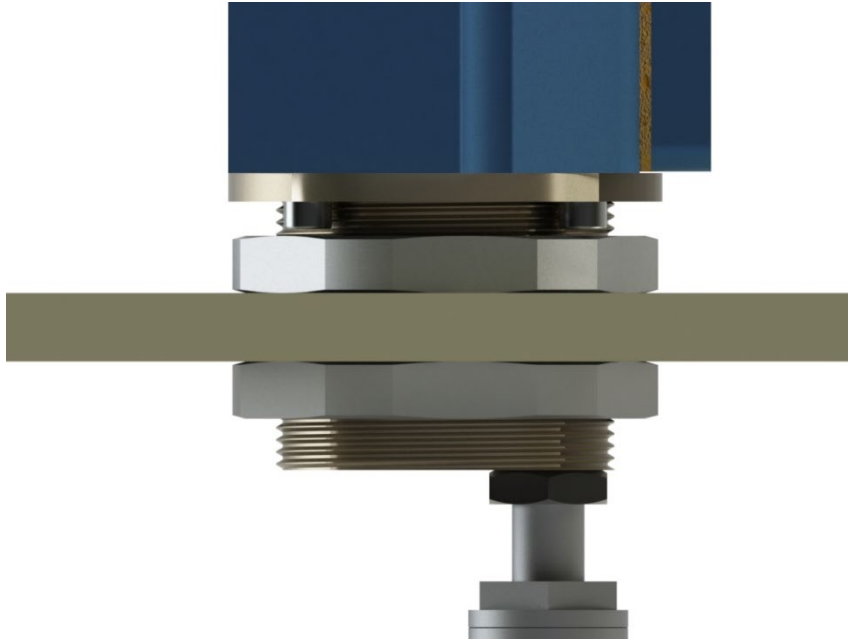

1. At a suitable position on the tank lid cut a 61mm diameter hole.
2. Screw one lock nut (3850) fully on to the DEAD-STOP valve until it is flush against the 4 cap heads at the top of the 2" BSP thread.
3. Place the DEAD-STOP with the top lock nut into the hole in the tank lid and align the valve body to the inlet pipework.
4. Underneath the tank lid, place the second lock nut (3850), and tighten against the bottom of the tank lid.
5. Check the valve is still aligned with the inlet pipework, if not loosen the top lock nut, rotate the valve and re-tighten.
6. Connect the inlet pipework using suitable flange components and tighten the 4 x M8 x 20mm bolts to 27Nm (20ft lbs) torque maximum.

ALWAYS USE NON-SPARK TOOLS!

RETRO-FITTING TO EXISTING TANKS:

Option A - For existing tank with weld socket

If the existing tank lid has a standard 2" weld socket opening the socket must be reduced to an overall height of between 25 mm and 30 mm - measured from the socket top face to the underside of the tank lid or socket lower face (whichever is greater).

Clean the thread with a 2" BSPP tap to obtain a hand fit for the valve cartridge.

DO NOT FORCE THE VALVE INTO A TIGHT THREAD.

Option B - to fit directly into tank lid using 2 x 2" BSP lock nuts

If the existing or new tank lid has a material thickness between 10 and 15 mm the DEAD-STOP can be fitted directly to the lid using 2 lock nuts (3850) either side, as shown in the installation instructions.

Option C - to fit directly into tank lid

If the existing or new tank lid has a material thickness between 10 and 25 mm the lid can be directly drilled and tapped 2" BSP parallel thread to BS 2779 1986 standard and a lock nut used to set the required alignment.

IMPORTANT NOTE.

Please note that the alterations to any tank must be completed in adherence with current Health & Safety Guidelines, Industry Regulations or Safe Working Practices.

Operation

- During the initial delivery check all inlet pipework and joints are leak free. The DEAD-STOP can be manually checked by raising the float into the shut position by hand and checking the flow stops.
- Maximum delivery pressure should not exceed 10 bar (145 psi).
- The DEAD-STOP valve exhibits the following characteristics during a delivery:
 - Unrestricted delivery until the float activation level is reached.
 - Once the maximum fluid level is reached the valve will shut completely, causing pressure to build up in pipework.
 - Once the valve is shut, the pressure in the pipework must dissipate and the fluid level must drop before the valve will reopen.

ALWAYS USE NON-SPARK TOOLS!

FOR REFERENCE.

Risbridger Ltd offer a range of tools specifically designed for Risbridger products. For further details please contact Risbridger,

For installation details of the products supplied with a DEAD-STOP and maintenance instructions, please see the following documents enclosed with the products or view on our website:

- DATA-DEAD-STOP
- MAINT-DEAD-STOP
- INS-DEAD-STOP-ADJUSTABLE-FLOAT

WARRANTY.

All RISBRIDGER Ltd products are guaranteed against defects in material and workmanship for a period of 12 months from the date of purchase subject to normal use and service. The sole obligation under this warranty is limited to repair or replacement, at the option of RISBRIDGER Ltd any product found to be defective upon examination provided that such product will be returned for inspection carriage paid, within three months of installation. Liability is strictly limited to replacement of defective parts manufactured by RISBRIDGER Ltd and no liability can be accepted for any loss or consequential damages arising from the installation or use of any products supplied by RISBRIDGER Ltd whatsoever the cause. This warranty shall not apply to any product subject to abuse, negligence, accident, misapplication or any alteration by others.

ALWAYS USE NON-SPARK TOOLS!

Risbridger

Quality Engineering Solutions

*Design innovation
Sound engineering
Integrity
Quality...for more
than*



Contact

+44 (0) 1737 372 680

info@risbridger.com

www.risbridger.com

Follow Us



Risbridger Ltd

25 Trowers Way
Holmethorpe Ind Est
Redhill
Surrey
RH1 2LH

Document Reference: INS-DEAD-STOP-231206